



Linyi High Tech Zone Lurun Water Purification
Equipment Co., Ltd



TANKLIFE®

Tanks **TLI TANK®**
For
Life

THE WORLD'S MOST PIONEERING, ALL-ROUND AND PASSIONATE RO TANK & PRESSURE TANK MANUFACTURER

PRODUCTS

TANKLIFE® Reverse Osmosis Tanks are manufactured with the highest rated FDA approved materials and most advanced technologies available. TANKLIFE® tanks are the global pioneer in introducing RO tanks with antibacterial butyl diaphragm properties. On top of that, our dust free operated workshop and post curing technologies ensure that any harmful materials are removed from every single diaphragm used in our tanks. This means if you choose TANKLIFE®, you choose the most chemical free and bacteria free RO tanks on the market today.

To guarantee long product life and optimal performance, TANKLIFE® tanks are manufactured with our patented precision welding technology. Combined with one of the highest mold thickness in the industry, this design means ultra strong structural integrity and a tank weld that always stays intact. To prevent air leaks, TANKLIFE® tanks are sealed with a double O-ring air charge valve. Therefore, TANKLIFE® offers the most safe and maintenance free solution for storing your purified water. TANKLIFE® tanks are available in plasteel, metal and plastic RO tank series.



TANKLIFE® PLASTEEL RO WATER STORAGE TANK SERIES

MODEL NO.	DIMENSIONS				TOTAL TANK VOLUME		SHIPPING VOLUME		SHIPPING WEIGHT	
	HEIGHT		DIAMETER		LITERS	GALLON	CBM	ft³	KG	LBS
	CM	INCH	CM	INCH						
TL – 15P	35.8	14.1	28.0	11	15	4.0	0.029	1.02	4.15	9.15
TL – 16P	38.5	15.16	25.0	9.8	16	4.2	0.028	0.98	4.00	8.82
TL – 19P	40.1	15.8	28.0	11	19	5.0	0.036	1.30	4.32	9.52

REMARKS : • Maximum Working Pressure 100 PSI • All Tanks pre-charged at 6 PSI • NSF APPROVED

FEATURES:

- ◆ Stainless steel water connector
- ◆ Antibacterial & post cured butyl diaphragm
- ◆ FDA & RoHS approved polypropylene liner
- ◆ Super strong internal steel layer
- ◆ Protective, FDA & RoHS approved polypropylene external cover
- ◆ Double O-ring brass air valve seal
- ◆ Wide-range testing at each production stage
- ◆ Compatible with all RO systems



TANKLIFE® PLASTIC RO WATER STORAGE TANK SERIES

MODEL NO.	DIMENSIONS				TOTAL TANK VOLUME		SHIPPING VOLUME		SHIPPING WEIGHT	
	HEIGHT		DIAMETER		LITERS	GALLON	CBM	FT ³	KG	LBS
	CM	INCH	CM	INCH						
TL-2.0G	37.00	14.57	16.00	6.30	7.57	2.00	0.009	0.32	1.40	3.09
TL-3.2GS	32.50	12.80	22.50	8.86	11.36	3.00	0.017	0.60	1.84	4.06
TL-3.2G	33.10	13.00	24.70	9.70	12.11	3.20	0.021	0.74	2.30	5.07
TL-4.0GS	36.10	14.17	25.30	9.96	14.38	3.80	0.024	0.85	2.50	5.51
TL-4.0G	38.20	15.00	27.20	10.70	15.14	4.00	0.029	1.02	3.00	6.61

REMARKS : • Maximum Working Pressure 50 PSI • All Tanks are pre-charged at 5 – 7 PSI • NSF APPROVED

- ◆ FDA & RoHS approved polypropylene raw material
- ◆ Patented pressure resistance technology, weld seam always remains intact
- ◆ Minimum 18 KG/1.8 Mpa/17.65 bar pressure strength
- ◆ Patented 8KG & 12KG diaphragm structural durability
- ◆ Antibacterial & post cured butyl diaphragm
- ◆ Industry leading mold thickness
- ◆ Double O-ring air charge valve
- ◆ Single unit molded tank base
- ◆ Extensive testing
- ◆ Compatible with all RO systems

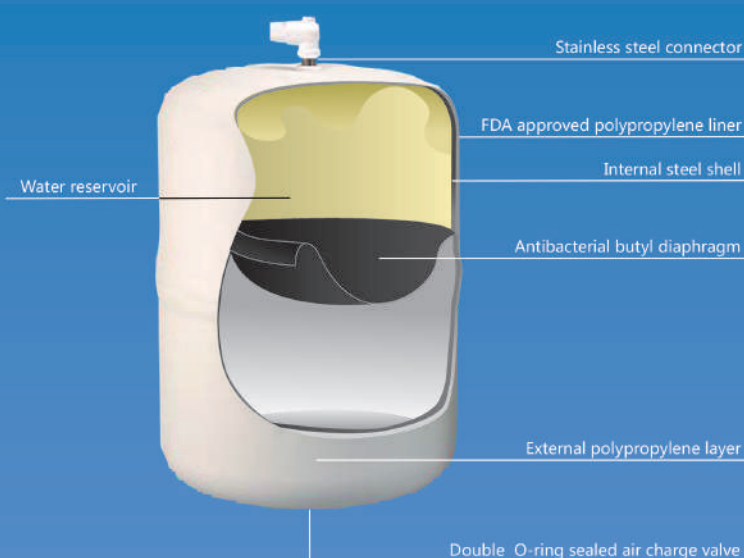
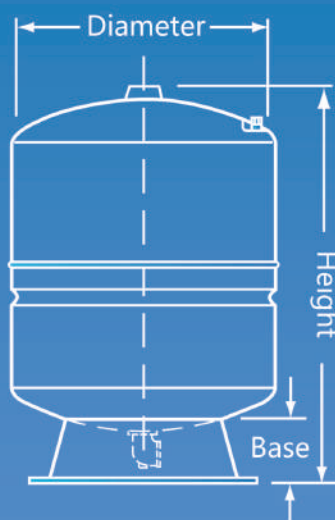
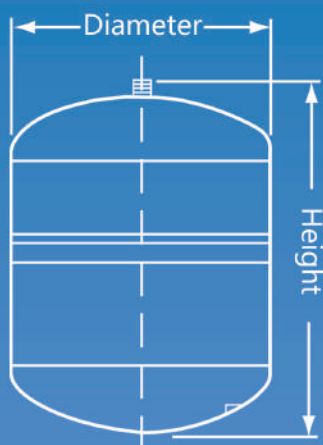

TANKLIFE® STEEL RO WATER STORAGE TANK SERIES

MODEL NO.	DIMENSIONS						TOTAL TANK VOLUME		SHIPPING VOLUME		SHIPPING WEIGHT	
	HEIGHT		DIAMETER		BASE		LITERS	GALLON	CBM	ft³	KG	LBS
	CM	INCH	CM	INCH	CM	INCH						
TL - RO122	35.5	13.98	22.8	8.98	3.5	1.38	10.6	3.2	0.021	0.74	2.75	6.06
TL - RO132	36	14.2	28	11	3.5	1.38	16.65	4.4	0.030	1.06	3.6	7.94
TL - 6G	44	17.32	28	11	3.5	1.38	22.7	6	0.036	1.27	4.2	9.26
TL - 11G	59	23.58	38.4	15.12	15.7	6.18	42	11	0.096	3.39	10	22.05
TL - 20G	79	31.18	38.4	15.12	15.7	6.18	80	20	0.128	4.48	12	26.46

REMARKS : • Maximum Working Pressure 100 PSI • NSF APPROVED

- ◆ Stainless steel water connector
- ◆ Antibacterial & post cured butyl diaphragm
- ◆ FDA & RoHS approved polypropylene liner
- ◆ Thick & strong external tank shell
- ◆ Double O-ring brass air valve seal
- ◆ Wide-range testing at each production stage
- ◆ Compatible with all RO systems

Reverse Osmosis Tank



TANKLIFE® K-SERIES INLINE FILTERS

TANKLIFE® K-series inline filters are made of FDA approved food grade polypropylene. The filter inlet and outlet connections are molded inside the filter body and cap as a single unit to prevent leakage. Spin welding techniques create a strong seal between the filter body and cap without the use of contaminants (glue etc.). Quick connect stem connections allow for hassle free installation in seconds. Grey rubber sponges protect the stem connections until the product arrives at the end-user. All filters include metallic look labels, which combined with a transparent packing for each filter create high aesthetic value and make our K-series inline filters appealing and appropriate for every drinking water treatment system.

PRODUCTS

- ◆ FDA approved polypropylene filter body
- ◆ Spin welded, contaminant free body & cap seal
- ◆ Quick-connect stem connections
- ◆ Rubber stem protections
- ◆ Metallic look shiny labels
- ◆ Transparent packing kit
- ◆ Multi-pack gift box available

TANKLIFE® K-SERIES FILTER SET



Filter Type	TLK – PP Inline	TLK – GAC Inline	TLK – CTO block Inline	TLK – RO* membrane Inline	TLK – UF membrane Inline	TLK – Coconut Post Carbon Inline
Size	11" X 2.5"	11" X 2.5"	11" X 2.5"	11" X 2.5"	11" X 2.5"	11" X 2.5"
Weight	255 Gram	420 Gram	400 Gram	355 Gram	350 Gram	350 Gram
OEM	Yes	Yes	Yes	Yes	Yes	Yes

REMARKS: • * Models 50/75/100 GPD

TANKLIFE® RO REPLACEMENT CARTRIDGE SERIES

- ◆ Compatible with all RO systems
- ◆ High quality filter media
- ◆ High carbon adsorption values
- ◆ Filter design benefits water flow rates
- ◆ Filters customized to your needs



Filter Type	PP sediment	GAC	CTO Carbon Block	Coconut Post Carbon Inline	Calgon Post-Carbon Inline
Size	10" & 20"	10" & 20"	10" & 20"	10" X 2"	10" X 2"
Weight	110 – 330 Gram	350 – 960 Gram	380 & 760 Gram	210 Gram	210 Gram
Filtration Media	FDA approved Polypropylene	Coal or Coconut based activated carbon	Coal based activated carbon	Coconut activated carbon	Calgon Coconut activated carbon
OEM	Yes	Yes	Yes	Yes	Yes

TANKLIFE® PRESSURE TANK SERIES

TANKLIFE pressure tank series consist of fixed diaphragm and replaceable diaphragm pressure tanks that are known globally under the TANKLIFE® and TLI® brands. By combining unique and innovative design features with smart and economic manufacturing solutions, our pressure tanks represent the best choice on the market for a wide variety of applications, including booster systems, boiler systems and thermal expansion, irrigation systems and hydraulic hammer arresting.

Fixed Diaphragm Pressure Tank Series

Model	Connection (inch)	Nominal Volume		Dimensions (mm)		
		Liters	Gallons	A	B	C
INLINE						
TLI-2LX	1" BSPT	2	0.53	208	126	-
TLI-5LX	1" BSPT	5	1.32	271	202	-
TLI-8LX	1" BSPT	8	2.11	314	202	-
TLI-12LX	1" BSPT	12	3.17	367	230	-
TLI-18LX	1" BSPT	18	4.76	367	278	-
TLI-24LX	1" BSPT	24	6.34	447	290	-
TLI-35LX	1" BSPT	35	9.25	481	319	-
HORIZONTAL						
TLI-24LH	1" BSPT	24	6.34	447	323	160
TLI-35LH	1" BSPT	35	9.25	481	353	192
TLI-60LH	1" BSPT	60	15.85	530	423	215
TLI-100LH	1" BSPT	100	26.42	720	475	245
VERTICAL WITH BASE						
TLI-35LV	1" BSPT	35	9.25	550	318	65
TLI-60LV	1" BSPT	60	15.85	624	388	67
TLI-100LV	1" BSPT	100	26.42	805	43	59

Replaceable Diaphragm Pressure Tank Series

Model	Connection (inch)	Nominal Volume		Dimensions (mm)		
		Liters	Gallons	A	B	C
TLHI-5LR	1" BSPT	5	1.32	285	160	-
TLHI-8LR	1" BSPT	8	2.11	355	200	-

*3/4" or other connection sizes available on request

** TLI-2LX: 12 pcs/box; TLI-5LX and TLI-8LX: 6 pcs/box

*** TLI-5LR: 8 pcs/box; TLI-8LR: 6 pcs/box

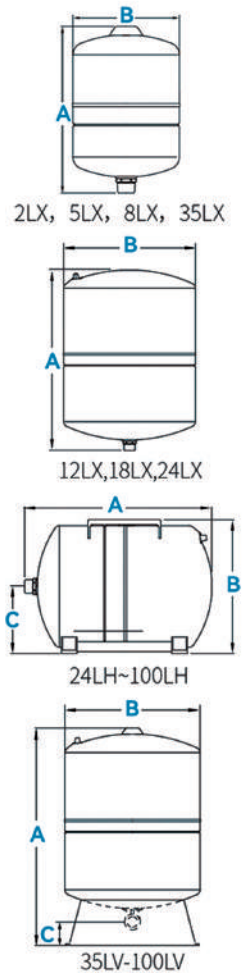

REMARKS : • Maximum Working Pressure 10 bar • All Tanks pre-charged at 1.9 bar

- ◆ Fixed diaphragm & replaceable diaphragm tank designs
- ◆ Reinforced stainless steel water connection
- ◆ O-ring sealed leak free air valve cap
- ◆ Durable & highly adhesive powder coating finish
- ◆ Suitable for a wide range of applications
- ◆ Extensively tested maintenance free tanks
- ◆ Fully made of food-grade and NSF/FDA approved raw materials





GLOBAL PRESENCE OF OUR PRODUCTS



TANKLIFE®
TLI™ TANK



Lurun Group is a leading high-tech manufacturer active in the drinking water treatment and baby care industry. The group consists of five members and two factories – based in Linyi, China – which together cover professional expertise in R&D, design, manufacturing and sales. Quality excellence is our golden rule, value adding solutions are our lifeline. We achieve this by combining our patented injection-molding and spin-welding expertise with a ‘partner’ s eye’ perspective: ‘Your growth is our growth’ & ‘bigger bang for your buck’ are our business principles.

Its subsidiary Lurun Water Purification Equipment Co., Ltd is one of the largest RO & pressure tank manufacturers globally. Our TANKLIFE® & TLI® tank series consist of plastic, steel and plasteel pressure tanks. TANKLIFE® tanks are manufactured with our patented structural integrity technology and use our globally pioneering antibacterial butyl diaphragm, to guarantee durable and bacteria-free tanks. All tanks are manufactured in our fully dust-free workshop. Other products include the TANKLIFE® inline filter and replacement cartridge series, which benefit from unique design features to make installation easier and performance more reliable.

All products are independently tested & certified, and use 100% authentic raw materials that meet the most respected global standards. Therefore, TANKLIFE® is your destination for drinking water system spare parts that are both healthy for you and aligned with your values.

Address: INTERSECTION OF XINHUA ST.& EHUANG ST., NEW HIGH TECH AREA, LINYI, SHANGDONG, CHINA, 276000

Website: www.lurunwater.com

Mob: +86 - 17705398544  

Email: mitch@luruncorp.com

Mob: +86 - 18754288927  

Email: frank@luruntanklife.com



WECHAT QR-CODE
+86 17705398544



WECHAT QR-CODE
+86 18754288927